



# The new Actros

6x4 Rigid

M-Cab ClassicSpace

2630, 2635, 2640, 2643, 2646

Mercedes-Benz

Trucks you can trust



# 6x4 Rigid

## M-Cab ClassicSpace

The extensive range of Rigid models from Mercedes-Benz Trucks set new standards in light-duty and local distribution haulage, thanks to its high efficiency and reliability. Designed to meet modern business needs, each model offers a versatile, application specific configuration for a wide range of sectors. The Rigid models from Mercedes-Benz Trucks are star-quality trucks ahead of their time.

### Models at a glance

Model	Engine and transmission	Cab	Weight front	Weight rear
Actros 2630	OM 936, 299hp + G211-12	M-Cab Classic 2.3 with 320mm tunnel	4,422	3,582
Actros 2635	OM 936, 354hp + G211-12	M-Cab Classic 2.3 with 320mm tunnel	4,422	3,582
Actros 2640	OM 470, 394hp + G211-12	M-Cab Classic 2.3 with 320mm tunnel	4,781	3,602
Actros 2643	OM 470, 428hp + G281-12	M-Cab Classic 2.3 with 320mm tunnel	4,826	3,614
Actros 2646	OM 470, 455hp + G281-12	M-Cab Classic 2.3 with 320mm tunnel	4,826	3,840

Weights include full AdBlue, 75kg driver, no fuel.



M-Cab ClassicSpace 2.30m, tunnel 320mm

## Model Specifications

### Engine

Engine Model	OM 936	OM 936	OM 470	OM 470	OM 470
Capacity	7.7l	7.7l	10.7l	10.7l	10.7l
Power	220kW (299hp)	260kW (354hp)	290kW (394hp)	315kW (428hp)	335kW (455hp)
Torque	1200Nm (885ft.lb)	1400Nm (1,033ft.lb)	1900Nm (1,401ft.lb)	2100Nm (1,549ft.lb)	2200Nm (1,623ft.lb)

## Cab

---

Multimedia cockpit

---

Truck navigation

---

Digital radio

---

Driver's suspension seat, standard

---

Fold-up co-driver's seat

---

Air conditioning system

---

Windscreen, tinted, with filter band

---

### Optional equipment

- Driver's suspension seat, comfort
  - Co-drivers suspension seat, comfort
  - Automatic climate control
  - Cab rear wall with window
  - Sun visor, exterior, transparent
  - Curtain, for rear wall window<sup>1</sup>
  - MirrorCam
  - Two additional remote control keys
  - Multimedia cockpit, interactive
  - Toolkit
  - Internal yellow grab handles
  - Construction-site filter
  - Mercedes star, illuminated from behind
  - Adjustable air deflectors
  - Air deflector, snap-in, with cab side deflectors
  - Cab roof air horns
  - Extended central locking
  - Compressed-air gun with hose
- 

## Driveline

---

G211 - 12 speed PowerShift Transmission with single plate clutch and 3.308 RAR engine RPM 1,710 @ 100km/h (only with OM 936)

---

G211 - 12 speed PowerShift Transmission with single plate clutch and 3.077 RAR engine RPM 1,591 @ 100km/h (only with 394hp)

---

G281 - 12 speed PowerShift Transmission with single plate clutch and 3.077 RAR engine RPM 1,591 @ 100km/h

---

### Optional equipment

- Predictive Powertrain Control
  - Power Take Off (PTO) MB 131-2c, pump
  - Engine Power Take Off (PTO), rear, c, hydraulic pump ISO 7653D
- 

## Front axle and suspension

---

7.5t offset front axle with 7.5t two leaf springs

---

## Rear axle and suspension

---

Two x 10.0t hypoid rear axle with differential locks, four bag rear air suspension

---

Two x 13.0t hypoid rear axle with differential locks, four bag rear air suspension (only with 455hp)

---

### Optional equipment

- Axle load measuring device<sup>2</sup>
- 

## Brakes

---

Disc brake, with Electronic Braking System (EBS)

---

Anti-lock Braking System (ABS)

---

Traction Control System (ASR)

---

High performance engine brake

---

Trailer brake, 2-line, brake connections, left

---

Stability control assist

---

Electronic park brake with HOLD function

---

### Optional equipment

- Independent trailer brake
  - Independent trailer brake, electronic
- 

## Wheelbase and frame

---

5500mm wheelbase with 2850mm rear overhang

---

### Optional equipment

- Wheelbase 5200mm<sup>3</sup>
  - Wheelbase 5800mm<sup>4</sup>
  - Frame overhang 3150mm<sup>5</sup>
-

## Electrical

---

Chassis mounted battery carrier left hand side

---

100A alternator with two 220Ah AGM batteries

---

2nd generation PSM (Body Interface Module)

---

Mercedes-Benz Telematics hardware and MB Uptime Assist

---

Mercedes-Benz Telematics 12 month complimentary access

---

Fleet Management System (FMS) gateway

---

Bi-xenon headlamps

---

LED daytime runnings light + LED tail light

---

Air horn, below cab

---

Frame mounted battery carrier left hand side

---

### Optional equipment

- Comfort telephony, wireless charging
  - 12V trailer lighting voltage reducer
  - UHF radio GME TX4500S
  - UHF radio GME XRS370C
  - Additional socket, 12V/15A, co-driver footwell
  - Body interface, behind cab
  - Floodlight, bottom
  - Pre-installation for rotating beacons
  - Pre-installation for additional headlamps, roof
  - Pre-installation for additional indicator lights
  - Pre-installation for flood lamp, cab rear wall
  - Pre-installation and display for up to four cameras
- 

## Safety

---

Front facing and kerb mirrors

---

Automatic park brake engage with door open and 0km/h

---

Automatic park brake engage with engine switch off

---

Driver airbag

---

Seat belt monitor

---

Rain sensor

---

Light sensor

---

### Optional equipment

- Safety Pack, inclusive of Lane Keep Assist, Attention Assist, Active Brake Assist 5, Proximity Control Assist, comfort driver's suspension seat and automatic main/dipped beam and cornering light
  - Tyre pressure monitor
- 

## Fuel, AdBlue and exhaust

---

390l aluminium fuel tank left hand side

---

60l AdBlue tank left hand side

---

Exhaust system, tailpipe to right and outwards

---

### Optional equipment

- Fuel tank, 290l, left hand side, 650W x 565H
  - Second tank, 290l, right hand side, 650W x 565H
  - Fuel tank, 500l, left hand side, 650W x 565H
  - Second tank, 500l, right hand side, 650W x 565H<sup>6</sup>
  - Fuel tank, 390l, right hand side, 650W X 565H
- 

## Wheels and tyres

---

8.25" x 22.5" steel rims with 295/80R 22.5 tyres

---

### Optional equipment

- 8.25" x 22.5" Dura-Bright rims
  - Spare rim and tyre
- 

## Maximum weights

---

OM 936 – 26,000kg GVM, 36,000kg GCM

---

OM 470 – 26,000kg GVM, 45,000kg GCM

---

## Warranty

---

2 year bumper to bumper with 4 year/800,000km driveline warranty

---

Chassis drawing and dimensions

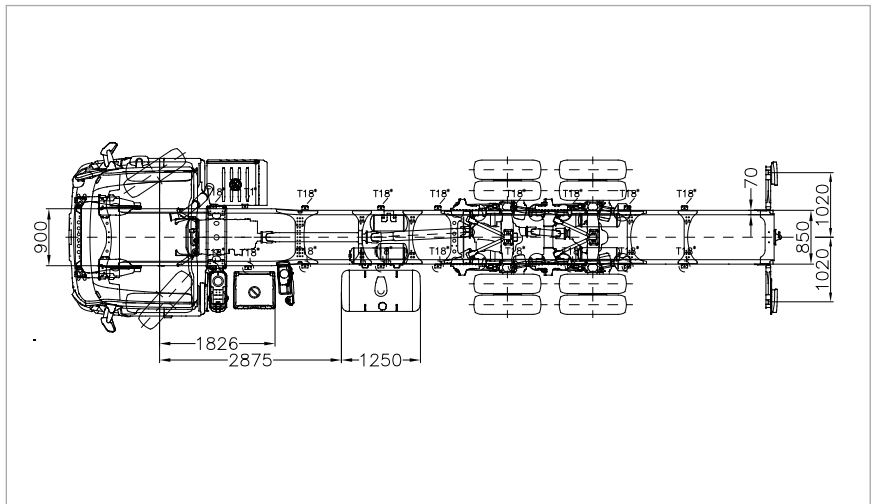
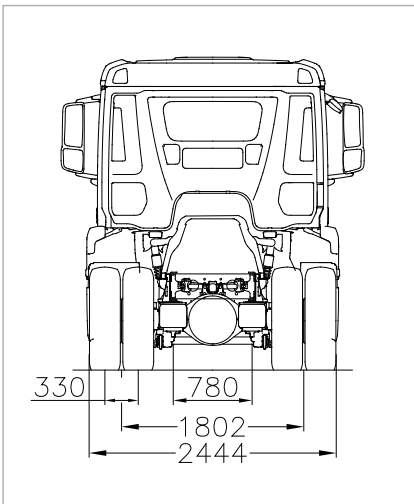
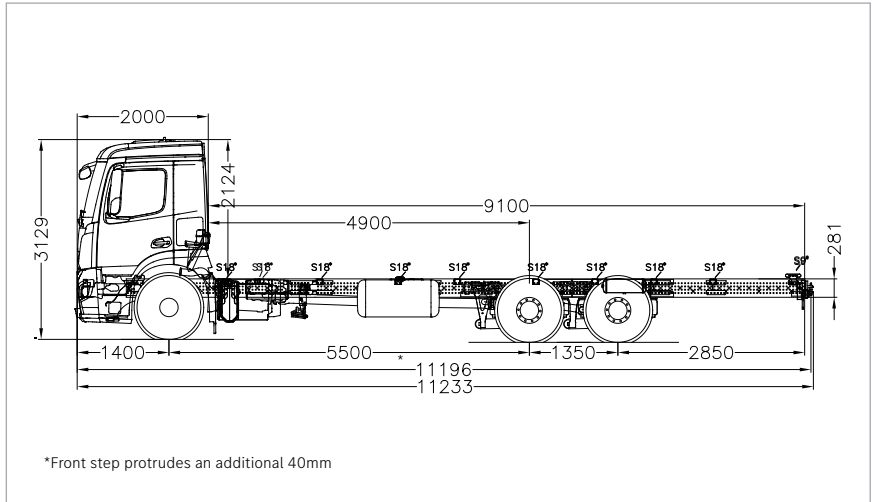
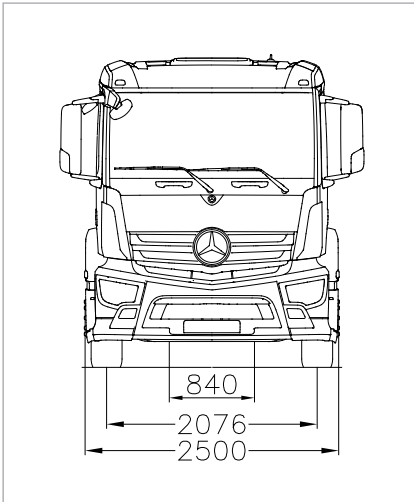

<sup>1</sup> Only with cab rear wall with window

<sup>2</sup> Indication only - not certified

<sup>3</sup> Overhang changes to 2250mm

<sup>4</sup> Steering wheel changes to 500mm, drivers bag not available

<sup>5</sup> Only with 5800mm wheelbase

<sup>6</sup> Only with 500l left tank

**Please note:** changes may have been made to the product since this publication went to press (November 2020). The manufacturer reserves the right to make changes to the design, form, colour, specifications to the vehicles or optional equipment without notice, including during the delivery period. The illustrations and texts may include accessories and items of special equipment which are not part of standard specification. Colours may differ slightly from those shown in the brochure, owing to the limitations of the printing process. The images shown are to be considered examples only and do not necessarily reflect the actual state of the original vehicles. The appearance of the original vehicles may differ from these illustrations. Subject to change. This publication may also contain models and services which are not available in certain countries. This brochure is distributed internationally. It provides a general indication of the range of models, features, special equipment and/or colours available in various countries. Some of the models, features, special equipment and/or colours may not be available in your country, or may only be available in a different specification. Additionally, some models, features, special equipment and/or colours may only be available in combination with others. Some equipment depicted either on vehicle illustrations or separately may be non-standard or options and may, where applicable, be available at an additional cost. For current and more specific information on the availability, design features and prices of all models, features, optional extras and/or colours available in Australia or New Zealand, you should contact your authorised Mercedes-Benz Truck Dealer on 1800 033 557 or go to [https://www.mercedes-benz-trucks.com/en\\_AU](https://www.mercedes-benz-trucks.com/en_AU) (Australia), or [https://www.mercedes-benz-trucks.com/en\\_NZ](https://www.mercedes-benz-trucks.com/en_NZ) (New Zealand).

Daimler Truck and Bus Australia Pacific Pty Ltd. Mulgrave, Victoria, Australia. ACN 618 413 282. Printed in Australia.